

P.O. Box 108, Mechanicsburg, IL 62545

DT-10

Phone - 217 / 364-4467 Fax - 217 / 364-4494

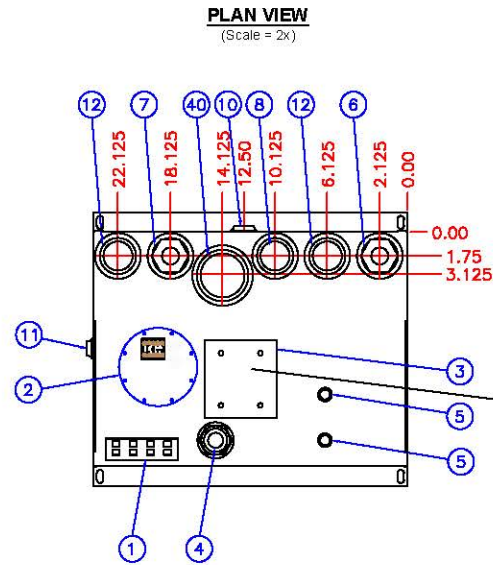

NOTE - PUMP & MOTOR NOT SHOWN IN ORDER TO REVEAL TANK OPENINGS

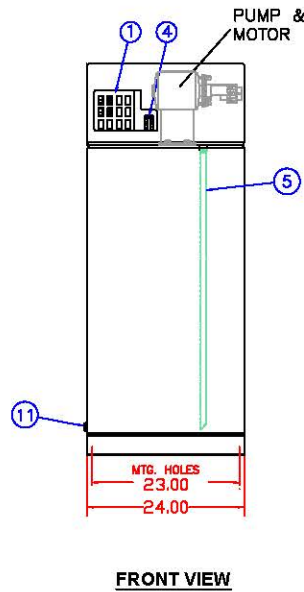
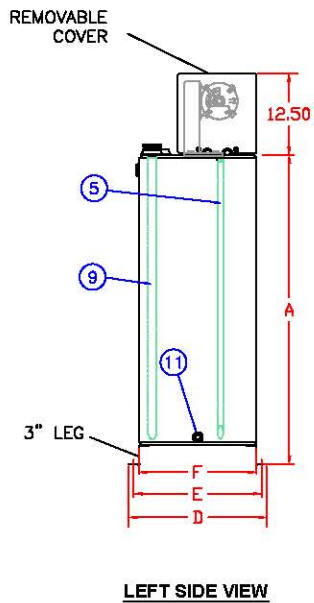

TANK DIMENSION REFERENCE CHART (SHOWN IN INCHES)

TANK RATED CAPACITY	A - HEIGHT (TANK)	D - DEPTH * (OVERALL)	E - DEPTH * (CTR-TO-CTR MTG HOLES)	F - DEPTH * (ACTUAL TANK)	U/L VENT NPT SIZE	WEIGHT ** BASIC TANK	WEIGHT ** U/L LISTED TANK
50 GAL.	33.50	21.00	19.50	18.00	2.00	193 LBS	197 LBS
60 GAL.	41.50	21.00	19.50	18.00	3.00	220 LBS	226 LBS
75 GAL.	46.50	21.00	19.50	18.00	3.00	236 LBS	243 LBS
100 GAL.	46.50	27.00	25.50	24.00	3.00	257 LBS	263 LBS
150 GAL.	46.50	39.00	37.50	36.00	3.00	302 LBS	309 LBS

* Depth dimension - Front-to-Back

** Approximate Weight (No Options) - Includes Pump, Motor & Related Controls

REF#	DESCRIPTION OF STANDARD EQUIPMENT
1	CONTROL PANEL
2	6-1/2" X 6-1/2" INSPECTION PLATE
3	6" x 6" MOTOR MOUNTING PLATE
4	1-1/2" NPT - FUEL LEV/EL GAUGE
5	FUEL INLET/OUTLET TO/FROM TANK w/DROP TUBES
6	2" x 1" NPT - ENGINE FUEL SUPPLY w/DROP TUBE
7	2" x 1" NPT - ENGINE FUEL RETURN w/DROP TUBE
8	2" NPT - TANK VENT TO ATMOSPHERE
9	1" NPT - DROP TUBES for ENGINE SUPPLY & RETURN
10	1" NPT - OVERFLOW TO MAIN STORAGE TANK
11	1/2" NPT - TANK DRAIN w/DROP TUBE (PLUGGED)
12	2" NPT - EXTRA CONNECTION
ADDITIONAL EQUIPMENT IF TANK IS U/L LISTED	
40	NPT CONNECTION FOR U/L EMERGENCY RELIEF VENT (See Above Chart For Size)

CONSTRUCTION NOTES

- 1 - TANK TOP, BOTTOM, & SHELL - 12 GAUGE STEEL
- 2 - DIMENSIONS SUBJECT TO CHANGE WITHOUT NOTICE

STANDARD SINGLE WALL DAY TANK
PY50 - PY150
PY50UL - PY150UL (U/L Listed Version)



DRAWN BY: RES | DATE: 03/01/2008
CHECKED BY: DJW | REV: 03/01/2008
SHEET NO. 1 of 1 | DWG #: STD_SW_B

Standard Single Wall Day Tank - PY50 thru PY150