

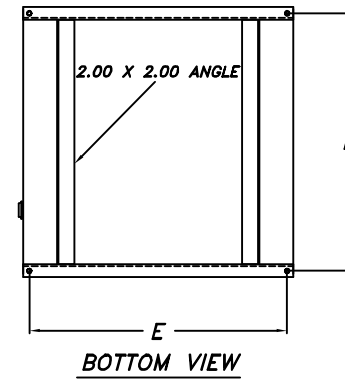

# 150 % RUPTURE BASIN

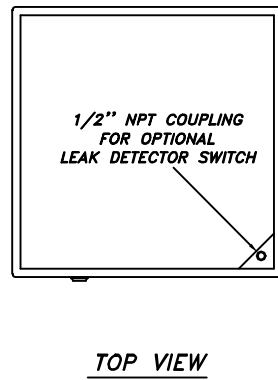
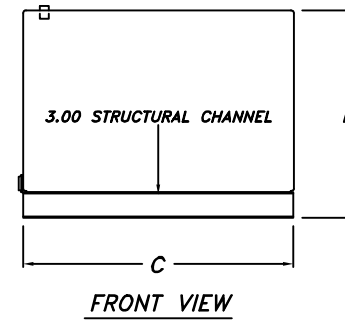
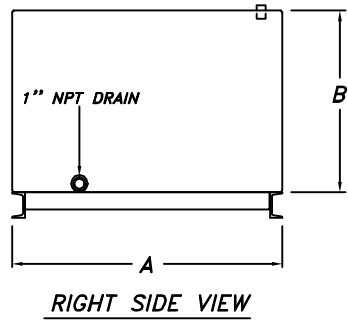

DIM.	5 GAL.	10 GAL.	15 GAL.	25 GAL.
A	14.00	20.00	20.00	20.00
B	6.00	8.00	9.00	14.00
C	32.00	32.00	32.00	32.00
D	9.00	11.00	12.00	17.00
E	30.50	30.50	30.50	30.50
F	12.50	18.50	18.50	18.50

RUPTURE BASIN ENDS,BOTTOM & SHELL - 12 GAUGE	
DIMENSION SUBJECT TO CHANGE WITHOUT NOTICE	
150% RUPTURE BASIN FOR PY10 - PY25 SINGLE WALL	
 <b>PRYCO, INC.</b> MECHANICSBURG, IL	
DIMENSIONS IN INCHES	DRAWN BY: RES CHECKED BY: R.J.W. DATE: 07-20-2000
	SHEET NO: 1 OF 1 SCALE: NONE DWG NUMBER: RB150-A SW