

FRONT VIEW

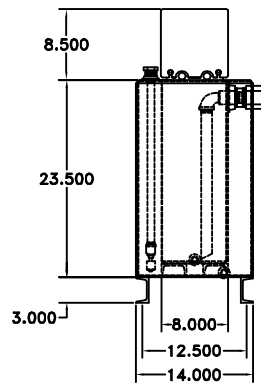

RIGHT SIDE VIEW

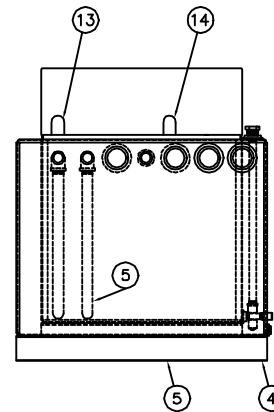

REAR VIEW

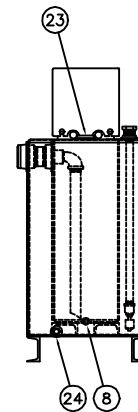

LEFT SIDE VIEW

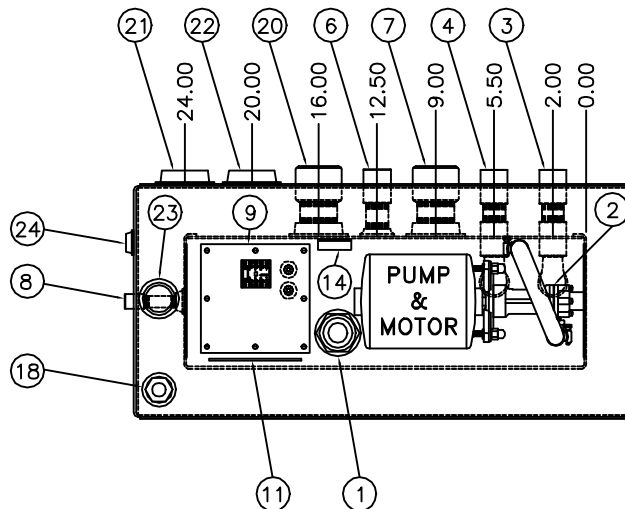

PLAN VIEW
(SCALE: 2X)

DESCRIPTION OF STANDARD EQUIPMENT	
1	1 1/2" NPT FOR FUEL LEVEL GAUGE
2	3/8" NPT FUEL INLET TO PUMP
3	1" NPT ENGINE FUEL SUPPLY W/PIPE STEM
4	1" NPT ENGINE FUEL RETURN W/PIPE STEM
5	1" NPT PIPE STEMS FOR ENGINE SUPPLY & RETURN
6	1" NPT OVERFLOW TO MAIN STORAGE TANK
7	2" NPT VENT FOR TANK TO ATMOSPHERE
8	3/8" NPT DRAIN FOR TANK (PLUGGED)
9	6 1/2" X 6 1/2" INSPECTION PLATE
10	PUMP AND ALARM SENSORS
11	CONTROL PANEL
12	REMOVABLE COVER
13	ELECTRICAL INLET THRU COVER
14	FUEL INLET THRU COVER
18	NPT FOR OPTIONAL LEAK DETECTOR SWITCH
22	2" NPT VENT FOR DOUBLE WALL TO ATMOSPHERE
23	1 1/4" NPT DOUBLE WALL INSPECTION FITTING (PLUGGED)
24	3/8" NPT DOUBLE WALL DRAIN (PLUGGED)
ADDITIONAL EQUIPMENT FOR U/L LISTED	
20	2" NPT U/L EMERGENCY RELIEF VENT FOR TANK
21	2" NPT U/L EMERGENCY RELIEF VENT FOR DOUBLE WALL
CONSTRUCTION NOTES	
TANK TOP,BOTTOM & SHELL - 12 GAUGE	
DIMENSIONS SUBJECT TO CHANGE WITHOUT NOTICE	
DAY TANK PY10T (10 GALLONS) TRIM WITH DOUBLE WALL	
 PRYCO INC. MECHANICSBURG, IL	
DRAWN BY: RES	SEE DRAWING: NONE
CHECKED BY: DJW	SCALE: 1=20
DATED: 7-24-2000	DWG. NUMBER: TRIM-PY10 DW