

FRONT VIEW

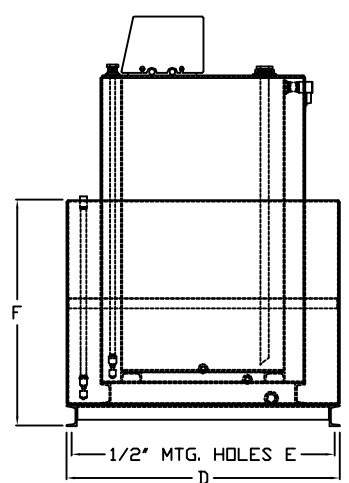

RIGHT SIDE VIEW

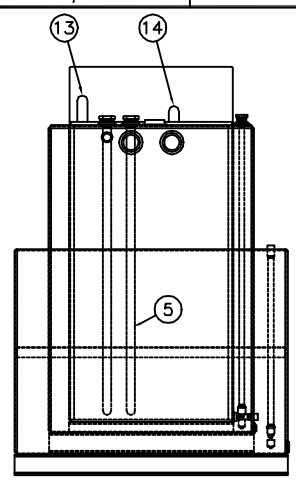

REAR VIEW

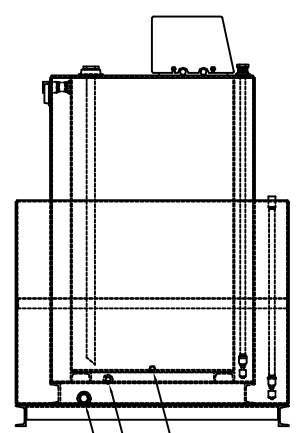

LEFT SIDE VIEW

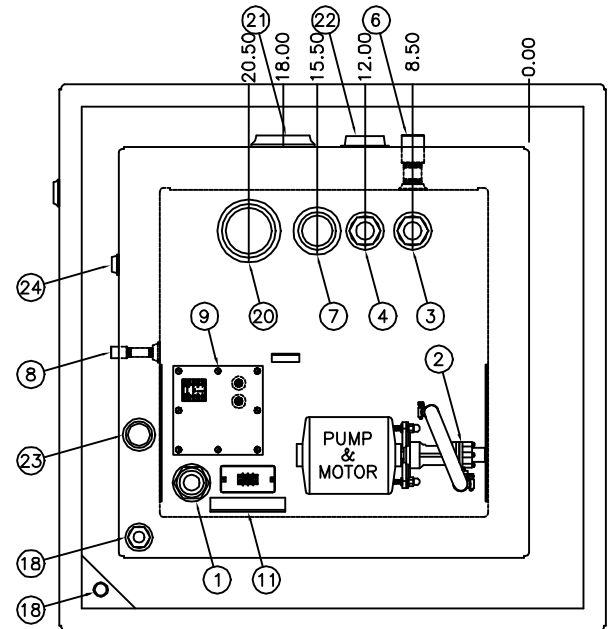

ENLARGED TOP VIEW

DIM.	50 GAL.	60 GAL.	75 GAL.	100 GAL.	150 GAL.
A	39.50	47.50	52.50	52.50	52.50
B	40.00	40.00	40.00	40.00	40.00
C	38.50	38.50	38.50	38.50	38.50
D	34.00	34.00	34.00	40.00	53.00
E	32.50	32.50	32.50	38.50	51.50
F	21.00	25.00	29.00	33.00	36.00
VENT	2"	3"	3"	3"	3"

DESCRIPTION OF STANDARD EQUIPMENT	
1	1 1/2" NPT FOR FUEL LEVEL GAUGE
2	3/8" NPT FUEL INLET TO PUMP
3	1 1/2" X 1" NPT ENGINE FUEL SUPPLY
4	1 1/2" X 1" NPT ENGINE FUEL RETURN
5	1" NPT PIPE STEMS FOR ENGINE FUEL SUPPLY AND RETURN
6	1" NPT OVERFLOW TO MAIN STORAGE TANK
7	2" NPT ATMOSPHERIC VENT FOR TANK
8	3/8" NPT TANK DRAIN
9	6 1/2" X 6 1/2" REMOVABLE INSPECTION PLATE
10	PUMP AND ALARM SENSORS
11	LOCAL CONTROL PANEL
12	REMOVABLE COVER
13	FUEL INLET THRU REMOVABLE COVER
14	ELECTRICAL INLET THRU REMOVABLE COVER
18	1" X 1/2" NPT FOR OPTIONAL LEAK DETECTOR
19	1" NPT DRAIN FOR RUPTURE BASIN (PLUGGED)
22	2" NPT ATMOSPHERIC VENT FOR DOUBLE WALL
23	1 1/4" NPT FOR DOUBLE WALL (PLUGGED)
24	3/8" NPT DOUBLE WALL DRAIN

ADDITIONAL EQUIPMENT FOR U/L LISTED	
20	U/L EMERGENCY RELIEF VENT FOR TANK (SEE CHART FOR SIZE)
21	U/L EMERGENCY RELIEF VENT FOR DOUBLE WALL (SEE CHART)

CONSTRUCTION NOTES
 TANK TOP,BOTTOM & SHELL - 12 GAUGE
 DOUBLE WALL TOP,BOTTOM & SHELL - 12 GAUGE
 DIMENSION SUBJECT TO CHANGE WITHOUT NOTICE

DAY TANK
 PY50 - PY150 (50 - 150 GALLONS)
 WITH DOUBLE WALL AND RUPTURE BASIN



DIMENSIONS IN INCHES	DRAWN BY: RES	SHEET NO: 1 OF 1
	CHECKED BY: D.J.W.	SCALE: NONE
	DATE: 07-21-2000	DWG NUMBER: STD-B DW RB