

FRONT VIEW

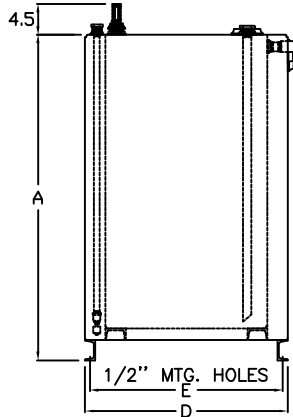

RIGHT SIDE VIEW

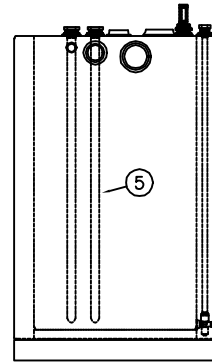

REAR VIEW

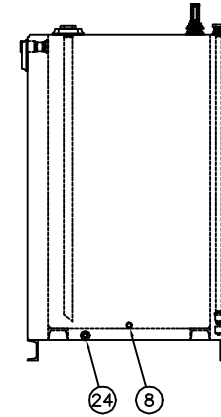

LEFT SIDE VIEW

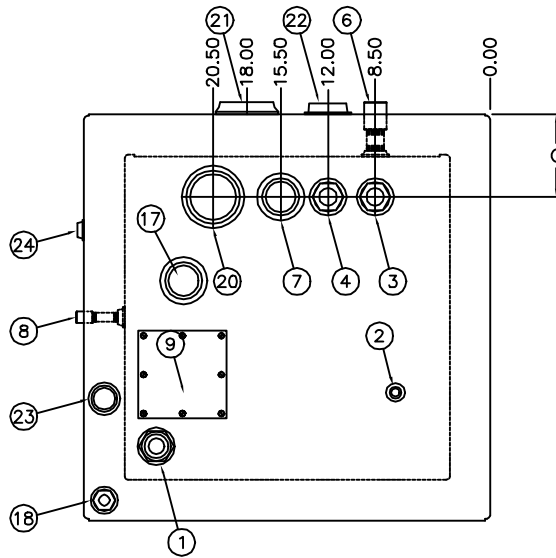

ENLARGED TOP VIEW

DIM.	50 GAL.	60 GAL.	75 GAL.	100 GAL.	150 GAL.
A	35.00	43.00	48.00	48.00	48.00
B	30.00	30.00	30.00	30.00	30.00
C	28.50	28.50	28.50	28.50	28.50
D	24.00	24.00	24.00	30.00	42.00
E	22.50	22.50	22.50	28.50	40.50
G	6.00	6.00	6.00	9.00	21.00
20	2"	3"	3"	3"	3"
21	2"	3"	3"	3"	3"

DESCRIPTION OF STANDARD EQUIPMENT	
1	1 1/2" NPT FOR FUEL LEVEL GAUGE
2	3/8" NPT FUEL INLET TO TANK (PLUGGED)
3	1 1/2" X 1" NPT ENGINE FUEL SUPPLY
4	1 1/2" X 1" NPT ENGINE FUEL RETURN
5	1" NPT PIPE STEM FOR ENGINE FUEL SUPPLY & RETURN
6	1" NPT OVERFLOW TO MAIN STORAGE TANK
7	2" NPT ATMOSPHERIC VENT FOR TANK
8	3/8" NPT TANK DRAIN
9	6 1/2" X 6 1/2" REMOVABLE INSPECTION PLATE
17	2" NPT FOR MANUAL FILL
18	1" X 1/2" NPT FOR OPTIONAL DOUBLE WALL LEAK DETECTOR
22	2" NPT ATMOSPHERIC VENT FOR DOUBLE WALL
23	1 1/4" NPT FOR DOUBLE WALL INSPECTION (PLUGGED)
24	3/8" NPT DOUBLE WALL DRAIN

ADDITIONAL EQUIPMENT FOR U/L LISTED	
20	U/L EMERGENCY RELIEF VENT FOR TANK (SEE CHART)
21	U/L EMERGENCY RELIEF VENT FOR DOUBLE WALL (SEE CHART)

CONSTRUCTION NOTES	
TANK TOP,BOTTOM & SHELL - 12 GAUGE	
DOUBLE WALL TOP,BOTTOM & SHELL - 12 GAUGE	
DIMENSION SUBJECT TO CHANGE WITHOUT NOTICE	

MANUAL DAY TANK
 PY50 - PY150 (50-150 GALLONS)
 WITH DOUBLE WALL



DIMENSIONS IN INCHES	DRAWN BY: RES	SHEET NO: 1 OF 1
	CHECKED BY: D.J.W.	SCALE: 1 = 25
	DATE: 07-20-2000	DWG NUMBER:MAN-B DW