

BRONZE CLOSE COUPLED ROTARY GEAR PUMPS

OBERDORFER PUMPS
GARDNER-DENVER THOMAS PRODUCTS DIVISION

**MODEL
N990
SERIES**

MODEL N990 - 1" NPT PORTS

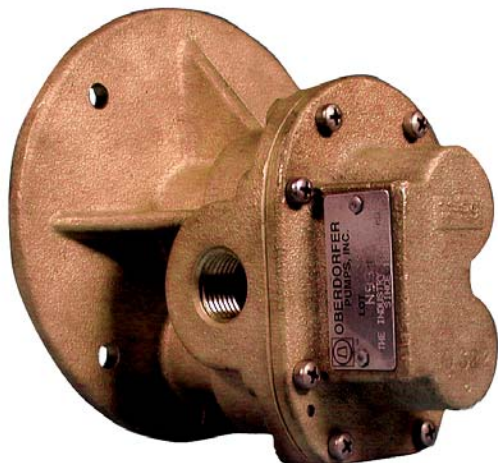

FEATURES

- Bronze Construction with Stainless Steel Shafts
- Helical gears for quiet operation
- Easy Field Assembly to Motors
- Self-Lubricating Carbon Bearings
- O-ring seal for max. leak protection
- For clutch version see N990-38
- For air motor driven version, see N990S15H-t34

GENERAL DESCRIPTION

Pump housings and gears are made of top quality bronze, shafts are stainless steel 303. Bearings are made of high performance carbon-graphite material selected for wear resistance and long service life.

Gear pumps are positive displacement pumps. Each shaft revolution displaces a definite amount of liquid relatively unaffected by the back pressure in the discharge line. Shaft speed and flow are directly proportional.

DRIVE ARRANGEMENT

Close coupled pumps are mounted directly to the electric motor by means of a suitable adapter bracket. The pump drive shaft is connected to the motor shaft by a flexible coupling.

LIQUIDS AND TEMPERATURE

These pumps are suitable for all liquids that are compatible with bronze. Most common liquids are water, oil, and mild chemicals in the pH-range of 4 to 11. Viscous liquids require reduced shaft speeds of 1150 RPM or lower. Consult factory.

Liquids containing solids, abrasives, powders or paint pigments are definitely not recommended for gear pumps. If abrasives are unavoidable, use a very low shaft speed. The recommended liquid temperature range is 32°F to 140°F for longest pump life. If more extreme temperature conditions exist, our factory should be consulted. Freezing of water-filled pumps can cause damage and must be avoided. Oils at low temperatures are very viscous requiring a lower speed or extra power.

PERFORMANCE

Water 70° F

PSI	GPM	1725 R.P.M.			Pump & Motor No.	
		HP Req.	HP Motor	Motor Frame	Single Phase	Three Phase
0	23.3	0.90	1	56C	N990HN26	N990HN95
20	22.9	1.19	1 1/2	145TC	N990JT45	N990JT95
40	22.5	1.53	1 1/2	145TC	N990JT45	N990JT95
60	22.1	1.92	2	145TC	N990JW45	N990JW95
80	21.7	2.25	3	182TC	N990KY45	N990KY95
100	21.3	2.70	3	182TC	N990KY45	N990KY95
125*	20.7	3.15	3	182TC	N990KY45	N990KY95
150*	20.1	3.70	5	184TC	N990KX45	N990KX95

PSI	GPM	1150 R.P.M.			Pump & Motor No.	
		HP Req.	HP Motor	Motor Frame	Single Phase	Three Phase
0	15.3	0.58	3/4	56C	N990HM46	N990HM96
20	15.0	0.77	3/4	56C	N990HM46	N990HM96
40	14.7	1.10	1	145TC	N990JN46	N990JN96
60	14.4	1.40	1 1/2	145TC	N990JT46	N990JT96
80	14.1	1.80	2	182TC	N990KW46	N990KW96
100	13.7	2.10	2	184TC	N990KW46	N990KW96
125*	13.1	2.60	3	213TC	N990LY46	N990LY96
150*	12.5	3.10	3	213TC	N990LY46	N990LY96

*For pressures over 100 psi, the above selections are suitable for pumping fluids with lubricity (e.g. oils, polymers). Service life will decrease for fluids without lubricity (e.g. water, solvents).

SUCTION LIFT

As a general rule, the suction lift should be kept at an absolute minimum by placing the pump as close to the liquid source as possible. A gear pump in new condition can lift 20 feet of water in the suction line. A foot valve (preferably with built-in strainer) is recommended at the beginning of the suction line. For a first start-up, the pump should be primed to avoid dry running. Minimum size of the suction pipe is the size of the pump inlet port. For longer suction lines (over 3 feet), or for viscous liquids, the pipe size should be at least one size or two sizes larger than the pump inlet port.

ROTATION AND RELIEF VALVE

The relief valve is not intended to be a metering or flow control device. Its main purpose is to function as a discharge pressure relief when the spring tension is exceeded by the discharge pressure. Overheating can occur within 5-10 minutes if the discharge line is completely shut off for extended periods.

Unless otherwise specified, the pump motor unit is supplied by the factory for shaft rotation clockwise from shaft end. Reversing the motor rotation will reverse the "in" and "out" ports and also requires changing the relief valve location. The relief valve is always on the discharge side in this pump series. The factory pressure setting is 50 PSIG. To increase pressure, turn the relief valve adjusting screw in a clockwise direction.

To reverse single phase motors, find instructions on the inside of the junction box cover or on the name plate of the motor.

Three phase motors are not wired for any particular rotation. They can be reversed by interchanging any two (2) wires of the three (3) wire leads.

**MODEL
N990
SERIES**

**BRONZE CLOSE COUPLED
ROTARY GEAR PUMPS**



OBERDORFER PUMPS
GARDNER-DENVER THOMAS PRODUCTS DIVISION

EXPLODED VIEW AND PARTS LIST

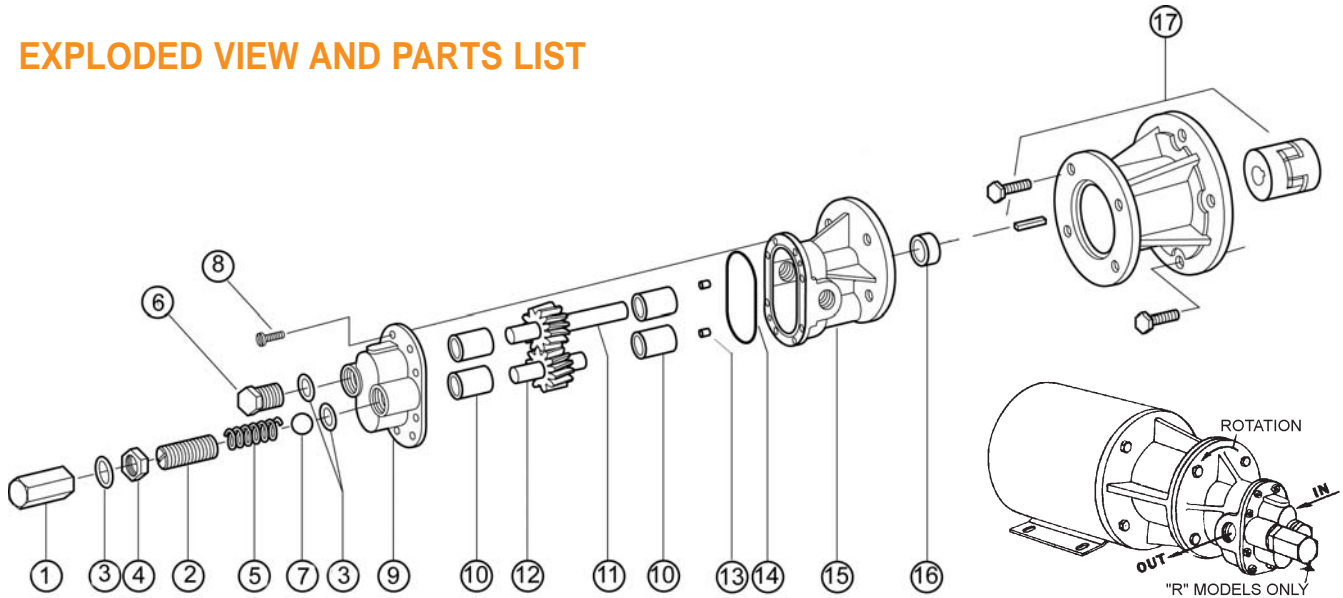

Pump No.	1	2	3	4	5	6	7	8	9	10 ¹	11 ¹	12 ¹	13	14 ¹	15	16 ^{1,2}	17
	Bypass Nut	Adj. Screw	Fiber Washer	Locknut	Spring	Plugnut	Ball	Screw	Cover	Bearing	Drive Gear Assy.	Idle Gear Assy.	Dowel Pin	O-Ring	Body	Lipseal	Adapter Kits
	1 Req'd	1 Req'd	3 Req'd	1 Req'd	1 Req'd	1 Req'd	1 Req'd	8 Req'd	1 Req'd	4 Req'd	1 Req'd	1 Req'd	2 Req'd	1 Req'd	1 Req'd	1 Req'd	
N990	---	---	---	---	---	---	---	5385	9326NN5N	5091	33026	33020	8885	9797-045	9328NF2N	5463	See
N990R	5276	5275	6965	1642	5277	5278	6217	5385	9327NN5B	5091	33026	33020	8885	9797-045	9328NF2N	5463	Below

¹ Repair kits contains items 10, 11, 12, 14 & 16. Repair kit for N990(R) is 12010.

² Part # 5463 is standard Buna N, part #9997 is Viton(R)*-Teflon(R)*.

Adapter Kits

Adapter Kit	Part Number	Description
H	11299	56C Frame
J	11300	143TC/145TC
K	11301	182TC/184TC
L	11302	213TC/215TC

Variations

Pump Model	16 ^{1,2} Lipseal	Description	Repair Kit
N990S15	9997	Viton(R)*-Teflon(R)*	12110
N990RS15	9997	Viton(R)*-Teflon(R)*	12110

Motor/Adapter Kit Dimensions (see below)

Model	Motor Frame	"A"	"B"	"C"
N990(R)H	56C	8.94	6.62	3.50
N990(R)J	143TC/145TC	8.94	6.62	3.50
N990(R)K	182TC/184TC	9.75	7.44	4.50
N990(R)L	213TC/215TC	9.75	7.44	5.25

DIMENSIONS

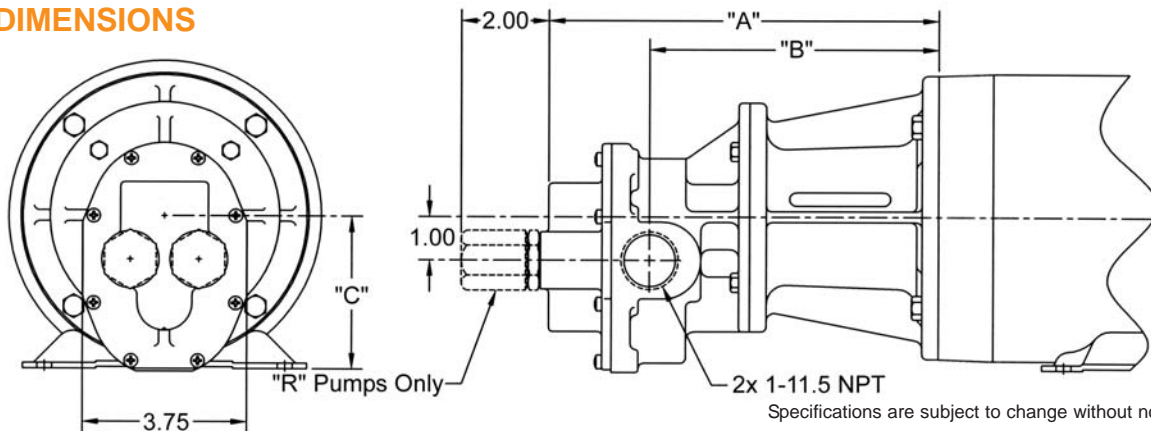

Specifications are subject to change without notice.

*Viton(R) or equivalent FKM will be used. Viton(R) is a registered trademark of DuPont Dow Elastomers. Teflon(R) or equivalent PTFE will be used. Teflon(R) is a registered trademark of DuPont.