



**PRYCO, INC.**

**P. O. BOX 108**

**Mechanicsburg, IL 62545**

**Telephone: 217 / 364-4467**

**Fax: 217 / 364-4494**

A grayscale photograph of a complex industrial pump set, featuring various pipes, valves, gauges, and a control panel. The image is semi-transparent, serving as a background for the title text.

**OPERATIONS  
AND  
MAINTENANCE  
MANUAL  
For  
PUMP SETS**

### WHAT TO DO FIRST

Upon receiving your new pump set system equipment, always check for physical signs of damages before signing the bill of lading. Inspect for possible damage that might have occurred during shipment. All products are inspected at point of shipment to ensure they are free of any defects. Dropping and other rough handling in transit could place stress or break welds and plumbing joints that will result in a failure. Check to ensure the system equipment arrives in good condition.

### THEN

Always have the fuel system installed by trained, authorized personnel. Remove shipping plugs from all connection fittings. Check to ensure any overflow line is continuous to the main storage tank without valves and traps (NFPA 37). Pryco fuel systems are designed for open venting. Make sure the vents are properly installed and unobstructed. Before starting the system, perform a final check of all pipe fittings for tightness. **IMPORTANT - Always clear fuel lines of debris resulting from pipe cutting and threading and other installation processes. Failure to do so may result in fuel contamination that will injure injectors and other engine components.**

### FINALLY

Record your model and serial numbers here and save this manual. The model and serial numbers are located on the embossed tag inside the electrical enclosure cover located at the upper right-hand corner of the pump set.

Model: \_\_\_\_\_ Install Date: \_\_\_\_\_

Serial Numbers(s) \_\_\_\_\_

### FACTORY TESTING PROCEDURES

During fabrication, Pryco systems are pressure tested at 5 psi of air pressure by quality control personnel.

All systems are carefully tested for proper operation. Power is applied to the unit and all aspects of the operation are tested. Alarms are tested by manually creating abnormal conditions in the sequences of operation. Components with contacts are tested for continuity during "closed" conditions. Pump motor controls are tested for start up and shut down of the motor. Proper rotation of the pump and motor are checked while in operation. All reset and test switches are checked for proper operation.

## PUMPS AND MOTORS GENERAL INFORMATION

---

**PUMPS** - The standard pump is a 2 GPM Bronze Gear Pump. Other pump models include: 4, 8, 10, 23, and 40 GPM. Each come with or without a pressure relief valve. This information generally applies to all models

The pump is driven directly from the shaft of the electric motor by means of a flexible coupling. An aluminum adapter connects the pump to the motor.

The pump is of bronze construction with stainless steel shafts, positive spring-loaded buna lip seals, and self-lubricating carbon bearings.

Due to close tolerances of components, fuel to the pump must be clean. Fine abrasives such as sand, silt, and powders in suspension will destroy its pumping ability. A **fuel strainer** (Pryco option # 314 or 315) should be installed just ahead of the pump (and solenoid valves, check valves, and other like devices) to keep debris from entering the system.

The pump's basic metals construction allow a temperature range of -40°F. to +400°F.; however, the buna lip seals have a temperature limit of +250°F. Avoid extreme temperatures and rapid fluctuations as they are detrimental to the pump's service life.

The pump is capable of creating 18 (plus) inches of vacuum on the suction side and up to 100 psi on the discharge side. Refer to pages 4 and 5 for a chart of the performance of each pump at 1725 RPM.

Before starting the system for the first time, you should apply some fuel oil through a **priming tee** to wet the pump gears. The fuel retained in the system lines and the gear chambers serve to wet the gears on subsequent starts.

---

**MOTORS** - The standard motor coupled to the pump has these characteristics: 1/3 HP, 115 VAC, 1 PH, 60 Hz, Thermal Protected, 6.6 FL Amps, 1.0 Service Factor.

The standard motor is special split phase with moderately high starting torque as well as a moderately high starting current. The thermal protected motors have internal, automatic protectors that will reset after the motor cools. Other motor configurations available range from 1/4 HP VDC motors up to 5 HP, 460 VAC. **Install power to the motor(s) according to National Electrical Code.**

### MOTOR LUBRICATION

Sleeve Bearings - re-oil using #5W-20 oil every 3000 hours of motor operation.

Ball Bearings - If the motor has provision for re-greasing, use a good grade of bearing grease every 2000 hours.

If lubrication instructions appear on the motor, they will supercede these instructions.

**Do not use unauthorized repair parts. These can affect proper and safe operation of the motor. Contact Pryco for replacement motors.**

**PUMP EXPLODED VIEW and PARTS LIST**  
 OPT #402 - 2 GPM, OPT #401 - 4 GPM, OPT #400 - 8 GPM

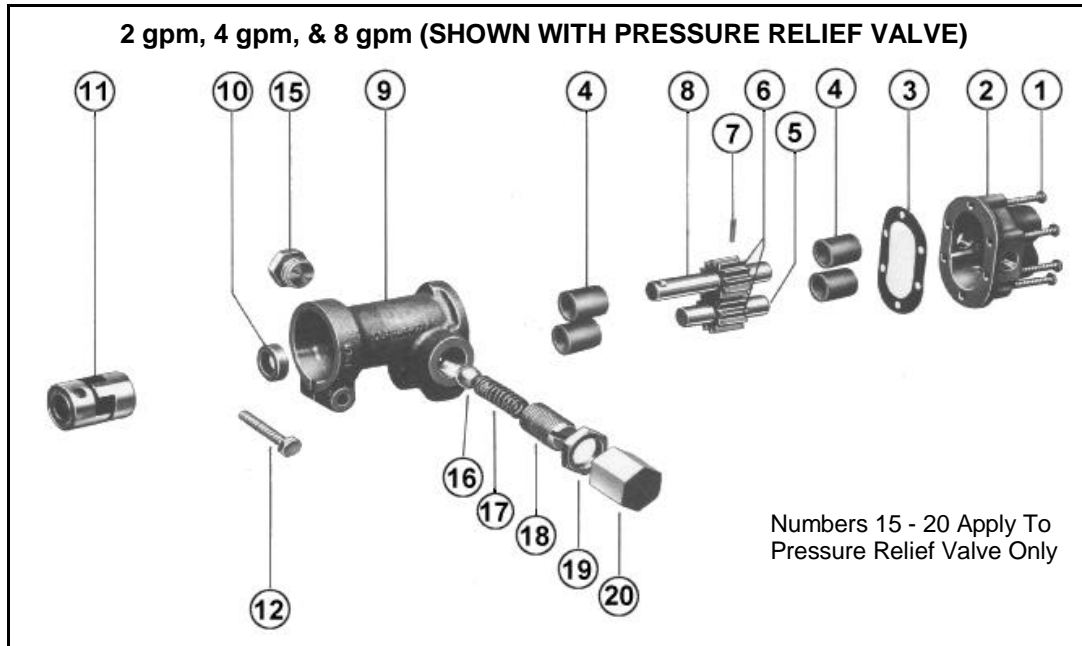

**PARTS LIST**

NO.	PART NAME	REQ.	NO.	PART NAME	REQ.	NO.	PART NAME	REQ.
1	Screw	6	7	Pin	1	15	Plug Nut*	1
2	Body	1	8	Drive Shaft	1	16	Ball*	1
3	Gasket	1	9	Cover	1	17	Spring*	1
4	Bearing	4	10	Seal	1	18	Adjusting Screw*	1
5	Idle Shaft	1	11	Coupling	1	19	Lock Nut*	1
				Screw	1	20	Valve Nut*	1

\* Parts For Pressure Relief Valve

**PUMP PERFORMANCE CHART - 1725 RPM MOTOR At 60° F.**

PUMP	PSI	2	20	40	60	80	100	125	150
<b>#402</b>	GPM	2.10	1.98	1.86	1.74	1.62	1.50	1.35	1.20
<b>2GPM</b>	HP REQ.	.05	.09	.14	.18	.23	.28	.33	.39
	MOTOR HP	1/3	1/3	1/3	1/3	1/3	1/3	1/3	1/3
<b>#401</b>	GPM	4.07	3.75	3.41	3.08	3.23	3.03	2.75	2.50
<b>4GPM</b>	HP REQ.	.10	.16	.22	.29	.36	.43	.55	.68
	MOTOR HP	1/3	1/3	1/3	1/3	1/2	1/2	3/4	3/4
<b>#400</b>	GPM	8.25	7.75	7.00	6.50	5.50	-	-	-
<b>8GPM</b>	HP REQ.	.38	.50	.73	.80	.95	-	-	-
	MOTOR HP	1/2	1/2	3/4	1	1	-	-	-

**PUMP EXPLODED VIEW and PARTS LIST**  
**OPT #403 - 10 GPM and OPT #404 - 23 GPM**

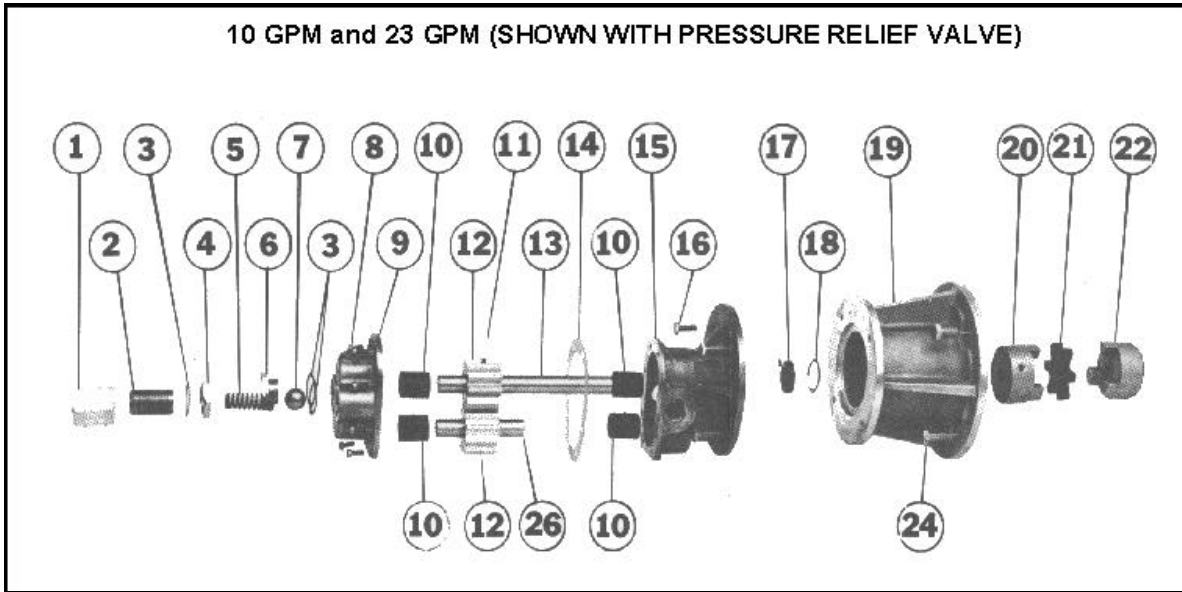

**PARTS LIST**

NO.	PART NAME	REQ.	NO.	PART NAME	REQ.	NO.	PART NAME	REQ.
1	Valve Nut*	1	9	Cover	1	17	Seal	1
2	Adjust Screw*	1	10	Bearing	4	18	Retaining Ring	1
3	Fiber Washer*	3	11	Pin	1	19	Adapter	1
4	Locknut*	1	12	Gear	2	20	Coupling Half-L	1
5	Spring*	1	13	Drive Shaft	1	21	Rubber Insert	1
6	Plug Nut*	1	14	Gasket	1	22	Coupling Half-R	1
7	Ball*	1	15	Body	1	24	Adapter Screw	4
8	Cover Screw	8	16	Body Screw	4	26	Idle Shaft	1

\* Parts For Pressure Relief Valve

**PUMP PERFORMANCE CHART - 1725 RPM MOTOR At 60° F.**

PUMP	PSI	2	20	40	60	80	100	125	150
<b>#403</b>	GPM	10.5	10.3	10.1	9.90	9.60	9.40	9.20	9.00
<b>10GPM</b>	HP REQ.	.05	.75	.90	1.20	1.50	1.75	2.00	2.32
	MOTOR HP	1/2	3/4	1	1-1/2	1-1/2	2	2	3
<b>#404</b>	GPM	23.3	22.9	22.5	22.1	21.7	21.3	20.7	20.1
<b>23GPM</b>	HP REQ.	.90	1.19	1.53	1.92	2.25	2.70	3.15	3.70
	MOTOR HP	1	1-1/2	1-1/2	2	3	3	3	5

**PUMP PERFORMANCE CHART - 1140 RPM MOTOR At 70° F.**

PUMP	PSI	10	20	40	60	80	100	125	150
<b>#405</b>	GPM	40-39	38	36	34	32	30	28	25
<b>40GPM</b>	HP REQ.	.90	1.1	1.7	2.3	2.8	3.5	4.3	5
	MOTOR HP	1	1-1/2	2	3	3	5	5	5

The information contained on the next two pages do not specifically pertain to a pump set. They are included to describe most likely actions that initiate various signals to a pump set to control pump motors (start, stop) and other devices.

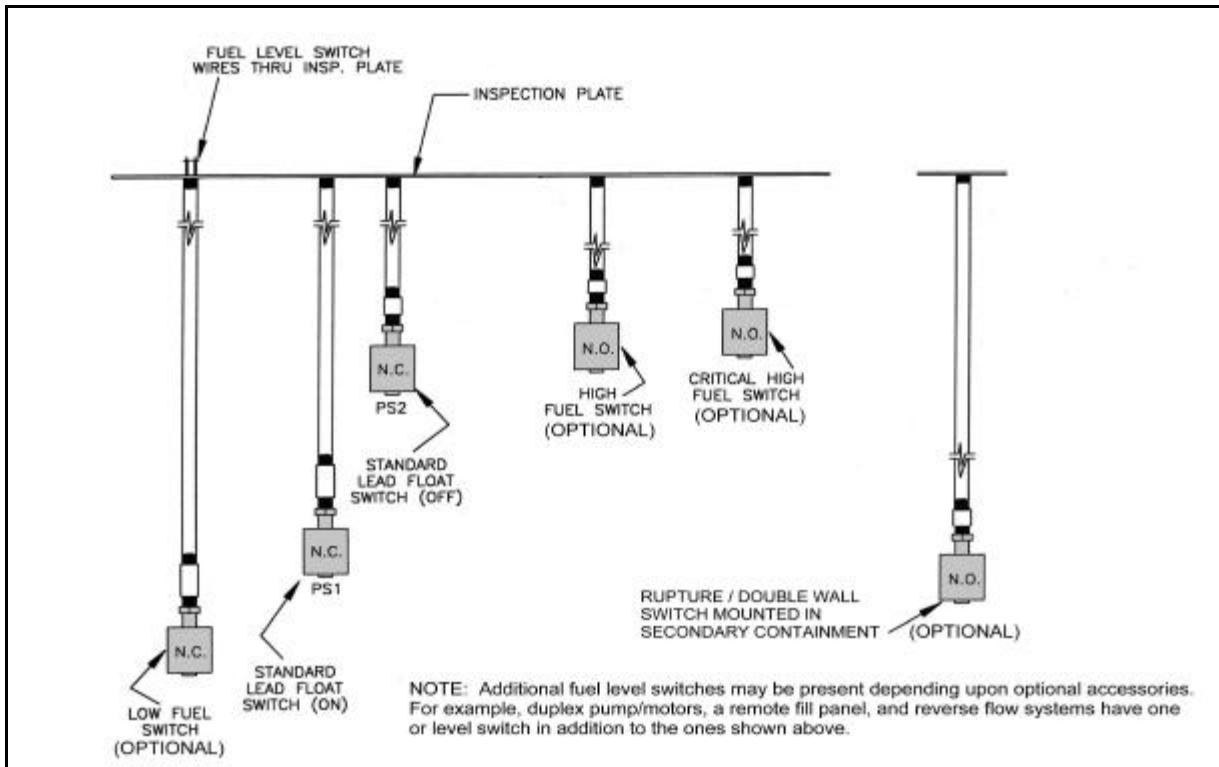

### GENERAL SEQUENCE OF OPERATION

When power is applied to the day tank, the pump/motor will begin to fill the day tank.

- ? As the fuel rises to the 86% level, the PS1 (Pump/Motor-ON) float switch opens and the tank continues to fill.
- ? When the fuel level reaches the 100% level, the PS2 (Pump/Motor OFF) float switch opens and stops the pump/motor.
- ? As the generator engine consumes fuel and the level drops to the 86% level, the pump/motor will fill the tank until the 100% fuel level is reached. PS1 turns on the pump/motor — PS2 turns it off.
- ? If the fuel level drops to 75%, the LOW FUEL SWITCH (option 203) closes allowing a light on the control panel to illuminate.
- ? If the fuel in the tank should reach 102% full, the HIGH FUEL SWITCH (Option 209) will close sending a high fuel level signal to the day tank terminal block.
- ? If the fuel level rises to 103%, the CRITICAL HIGH FUEL SWITCH (option 213) closes allowing the following:
  - a Critical High Fuel light on the control panel to illuminate,
  - a N.O. solenoid valve will close causing the pump/motor to stop, and
  - a set of dry contacts, to be used for remote annunciation, will become active.
- ? If the fuel rises to 5% in the secondary containment (if installed), the RUPTURE ALARM SWITCH (option 395) closes allowing the following:
  - a Rupture Alarm light on the control panel to illuminate,
  - the pump/motor to stop, and
  - a set of dry contacts, to be used for remote annunciation, will become active.

CHANGE FUEL LEVEL SWITCH FROM N/C TO N/O		
1. REMOVE RETAINER CLIP FROM BOTTOM OF FLOAT 2. REMOVE FLOAT FROM STEM, TURN UPSIDE DOWN 3. SLIDE FLOAT BACK ON STEM, INSTALL RETAINER CLIP		
CURRENT AND VOLTAGE RATING		
WATTS	VOLTAGE	CURRENT AMP RESISTIVE
30	220 AC	0.14
	110 AC	0.28
	120 DC	0.07
	24 DC	0.28
NOTE: ABOVE RATINGS ARE FOR RESISTIVE LOADS ONLY. FOR INDUCTIVE LOADS, MAXIMUM LIFE WILL BE ACCOMPLISHED IF PROPER ARC SUPPRESSION IS USED.		
MAXIMUM VOLTAGE RATINGS:  SPST - 220 VAC SPDT - 120 VAC		

NORMALLY OPEN

NORMALLY CLOSED

## FUEL LEVEL SWITCH

Pryco fuel level switches are accurate and dependable. They are made of Buna-N and polybutylene terephthalate (PBT) — a combination for use in diesel oil. The fuel level switches are mounted on 1/8" NPT black pipe nipples extending through a 5" x 5" inspection port on the top of the day tank.

If for some reason a switch becomes inoperable, follow these steps for replacement:

- 1 Disconnect power to the day tank control circuits.
- 2 Locate, using the supplied wiring diagram, the contactor, relay, terminal block, or similar component to which the inoperable level switch is attached, and disconnect the two black wires.
- 3 Remove the eight 1/4" bolts securing the 6 1/2" x 6 1/2" inspection plate that is located on top of the tank.
- 4 Remove the inspection plate being careful not to damage existing wiring.
- 5 Locate the fuel level switch that is inoperable and remove it from the pipe coupling.
- 6 Using a continuity tester, ensure the proper positioning of the level switch float. If there is continuity where there should not be, remove the retainer clip, turn the float over (end for end) and replace the retainer clip (see instruction at the top of this page).
- 7 Install fuel level switch to the pipe coupling.
- 8 Re-attach the wires removed in step 2.
- 9 Re-install inspection plate and bolt to tank.
- 10 Re-test all day tank functions and ensure proper operation.

PRYCO, INC.

## **WARRANTY**

PRYCO, INC.

All sales by **PRYCO, INC.**, are subject to the following terms and conditions as its Warranties:

**PRYCO, INC.**, warrants that its products shall be as represented in its catalog and warrants its products against defects in workmanship and materials under normal use and conformance with manufacturer's instructions for installation and use for a period of one year from date of sale determined by invoice date and which **PRYCO's** examination shall disclose to its satisfaction to be thus defective.

This remedy is agreed by Buyer and **PRYCO** to constitute a sole and exclusive remedy and all sales are made subject to the condition that **PRYCO** is not liable for consequential damages or for personal injuries of its customers or others.

**PRYCO** will not warrant installation of fuel tank. Alteration of design or repairs without written authorization will void warranty.

During such period, **PRYCO** will repair or replace, at its option, such defective parts without charge to buyers, provided buyer pays shipping charges for return of such products to **PRYCO**.

Electrical parts are warranted only to the extent of the warranty provided by their respective manufacturers of such parts.

***THIS WARRANTY IS EXPRESSLY IN LIEU OF ALL OTHER WARRANTIES, EXPRESS OR IMPLIED, INCLUDING THE WARRANTY OF MERCHANTABILITY, FITNESS OR PRODUCTIVENESS. THIS WARRANTY SHALL NOT APPLY TO ANY PRYCO PRODUCT OR ANY PART THEREOF WHICH HAS BEEN THE SUBJECT OF ACCIDENT, NEGLIGENCE, ABUSE OR MISUSE. PRYCO WARRANTY IN RESPECT TO ACCESSORIES OR PARTS NOT SUPPLIED BY PRYCO. THERE ARE NO OTHER WARRANTIES WHICH EXTEND BEYOND THE DESCRIPTION ON THE FACE HEREOF.***

# **PRYCO, INC.**

**P. O. BOX 108**

**Mechanicsburg, IL 62545**

Telephone: 217 / 364-4467

Fax: 217 / 364-4494